

NEW
Product
LAUNCH

AI-30

THE FOURTH GENERATION TRUNK LINE OPTICAL FIBER FUSION SPLICER

Built-in high precision

Delay return electric one-step fiber cleaver



Higher precision motors

Clearer lenses

More powerful chips

More efficient algorithms

More accurate fiber core recognition

Accurate of fiber alignment:0.05 μ m

Full link integration design

Highly integrated

The AI-30, the fourth generation fiber fusion splicer developed by Signal fire, is the latest generation of fiber fusion splicer designed for full link integration. It combines Signal fire's latest research and development of a delayed return electric one-step cleaver with fiber fusion splicing, while integrating OPM and VFL functions. Combined with a nine in one signalfire fiber stripper, a combinable workbench and worktable, it truly becomes a compact, lightweight, and easy to operate fiber fusion splicer, which will greatly improve your work efficiency.



SIX MOTORS



FIBER CORE
ALIGNMENT



6S SPLICING



15S HEATING



WITHIN OPM
FUNCTION



WITHIN VFL
FUNCTION



DELAY RETURN ELECTRIC
ONE-STEP FIBER CLEAVER



SIGNAL FIRE
STRIPPER

Humanized design meets different Construction environments



Compact and portable



Climbing high is also easy



Bench+support platform



Can be used as a bench



Host support /protection console



Equipped with signal fire stripper



Signal fire AI-30 fusion splicer applies multiple of the latest patented technologies of Signal fire, and adopts a more advanced central processing unit, more advanced algorithms, and higher precision cameras. Especially, the AI-30 fiber core is clearer and more visible, and the fusion loss and stability are better. It is fully capable of longer distance mainline fiber optic cable fusion splicing projects. The weight of bare machine, tool case and complete set of accessories only 4.5kg, size of tool case is 25.5cmx16.5cmx23cm. In such a compact and compact situation, the combination design of workbench and bench has been achieved simultaneously. 1 second startup, 6 seconds rapid fusion, 15 seconds heating, 5-inch color high-definition LCD screen, 320x magnification, 7800mAh large capacity lithium battery can fuse and heat 240 cores, still performs well in harsh environments such as high altitude, dry, and cold.

Exquisite craftsmanship High standard design



The buttons are clear and beautiful

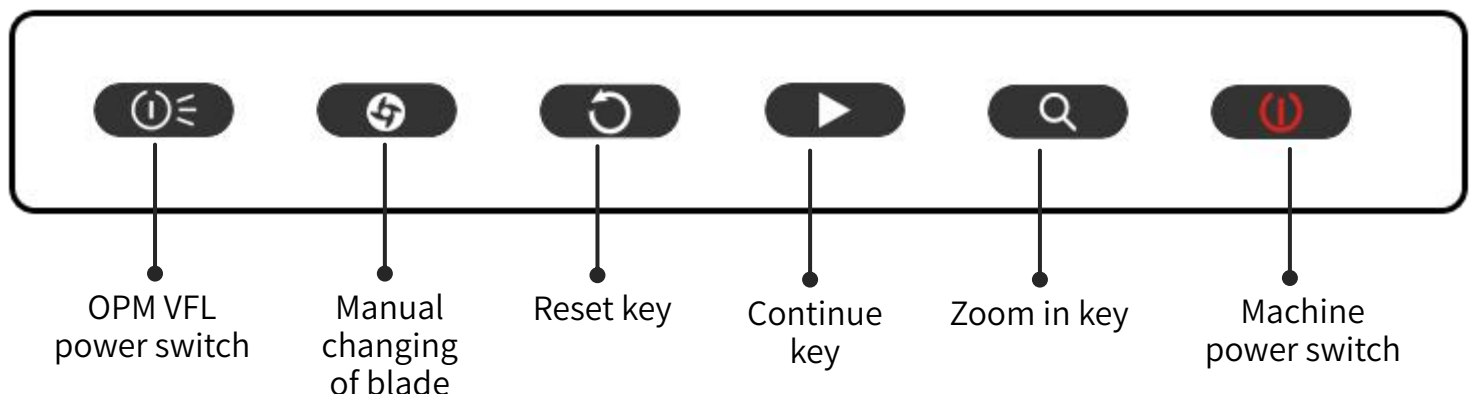

Display 5 inch TFT color display screen

320X (X or Y axis single display) 200X (X and Y axis dual display)

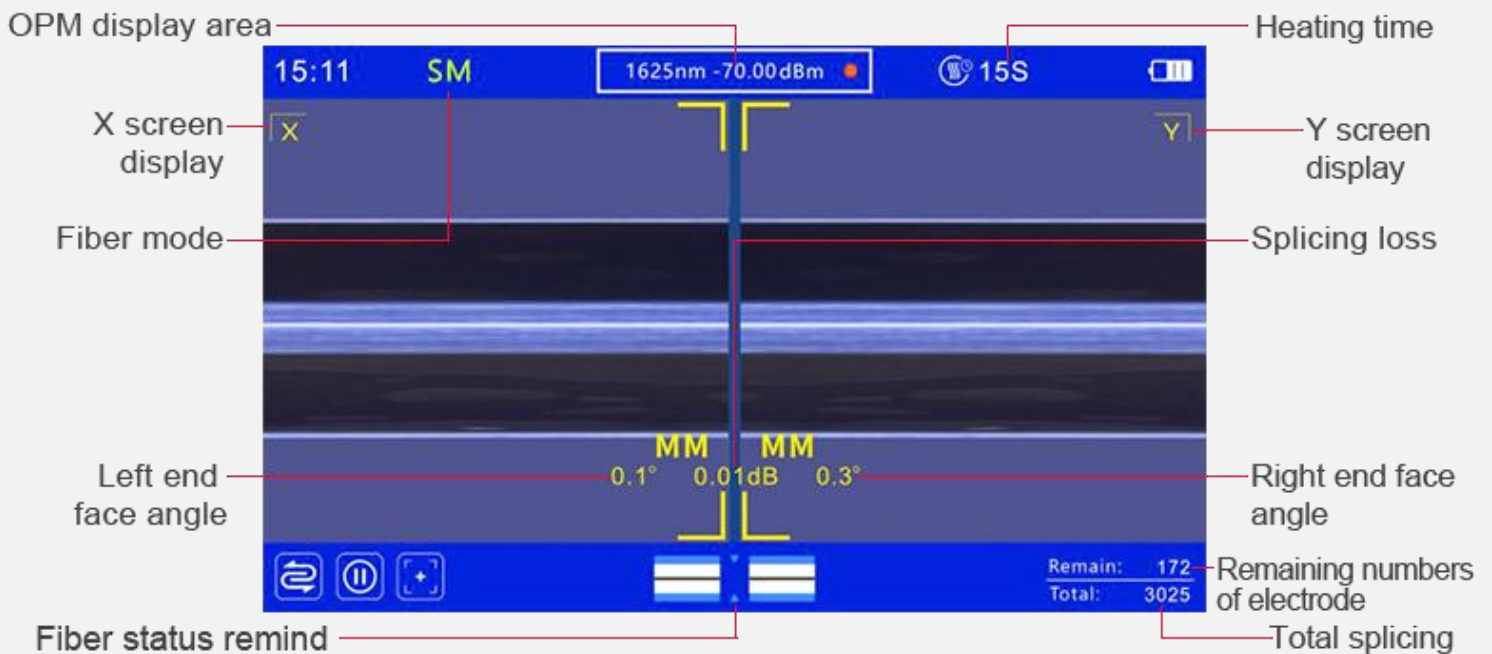

Camera failure



Core align failed



Focus failed



ARC calibration failed



Left and right fiber does not match



The lens is foggy or foreign body interference

Built-in high precision delay return electric one-step fiber cleaver

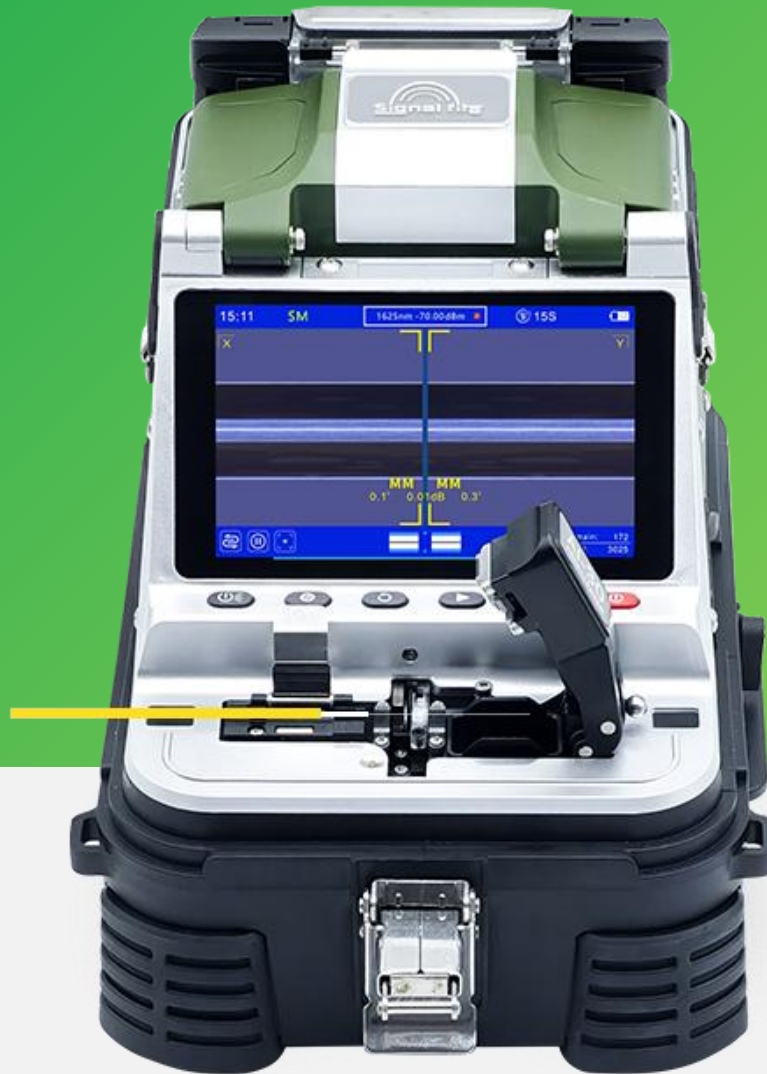

Signal fire new generation fiber fusion splicer has significantly reduced the actual weight and volume of the entire equipment by reducing auxiliary tools and improving the automation level, ultimately achieving a true improvement in fusion quality and efficiency. This is the fourth generation fiber fusion splicer that we first launched, and the core is full link integration design, highly integrated.

Blades surface automatically manually change delayed cleaver return

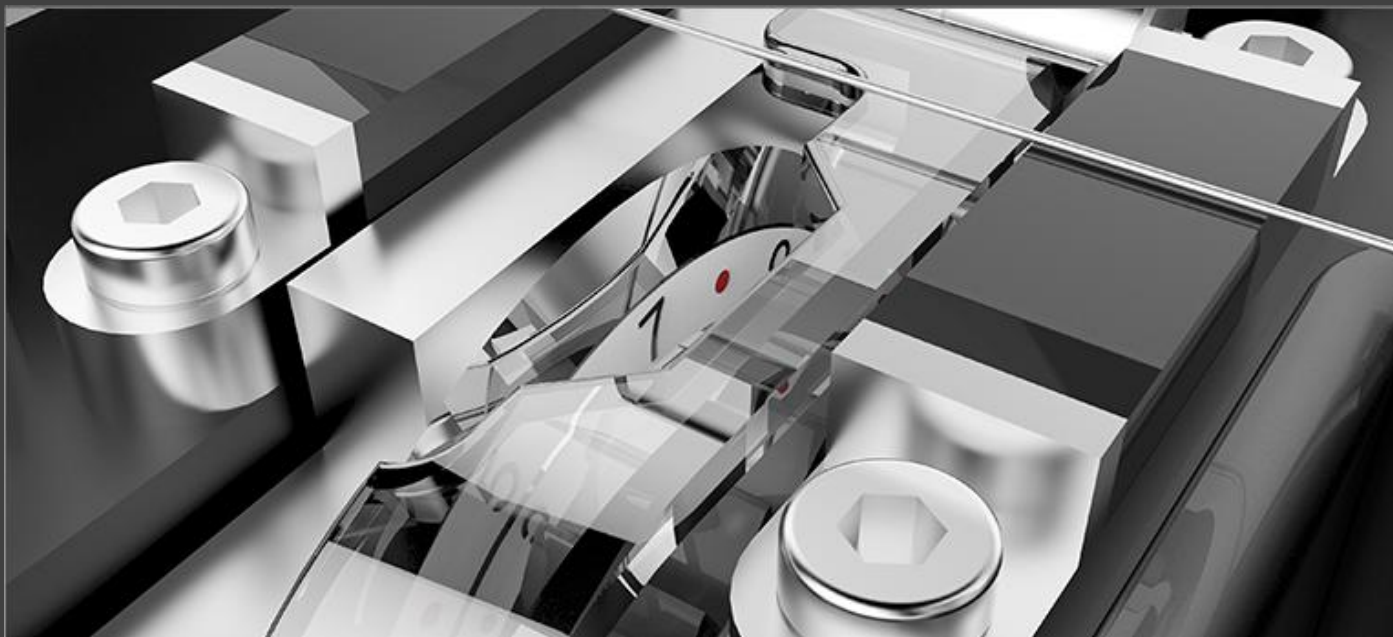

AUTOMATIC CHANGE

Cleaver blades surface automatically change when the current cutting point cut fiber more than 1000 times and continuously shown three times unqualified cutting results.

MANUAL CHANGE

Manual button operation, cleaver blades surface will change. Cleaver has 24 cutting points in total, current cutting point cut numbers, blades total cut numbers, Available within the APP.



AUTOMATIC DELAYED CLEAVER RETURN

Perfectly solves the problem of traditional mechanical one-step cleaver back cutting scratching the fiber end face. The factory standard delay time is set to 0.5 seconds, and the adjustable range is 0.2 seconds to 2 seconds.

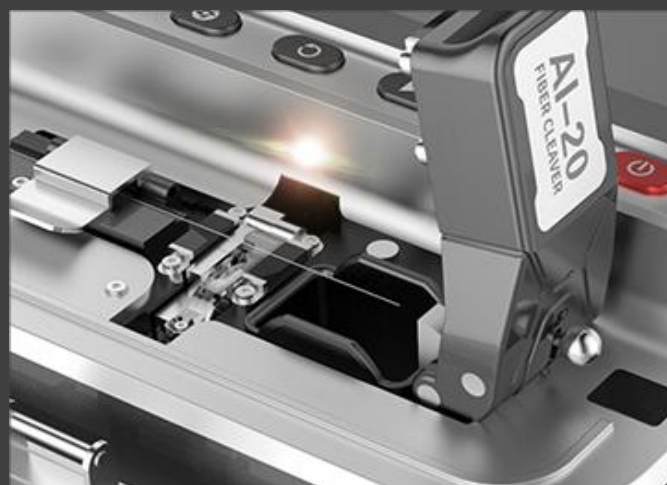

CLEAVER LED AUXILIARY LIGHTING

Brightness can be adjusted through APP.

APP Bluetooth connection

< System parameters Save

Blade change stroke Value range 10 ~ 100

Cutter face change stroke Value range 10 ~ 100

Cutting speed Value range 1~5

Return blade delay ms Value range 200 ~ 2000ms

Blade usage details and rotating blade face >

Replace the blade >

How to adjust blade height >

LED brightness adjustment 

< cutter setting

Total number of cuts 12598

Number of times the current blade has been used: 2610

Current point: 5

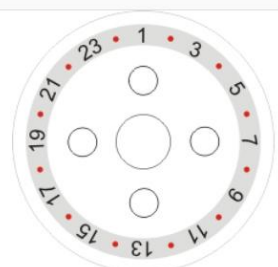

Built-in VFL and OPM function

Measure fiber link loss/luminous flux
Fiber line tracking, breakpoint/light leakage detection

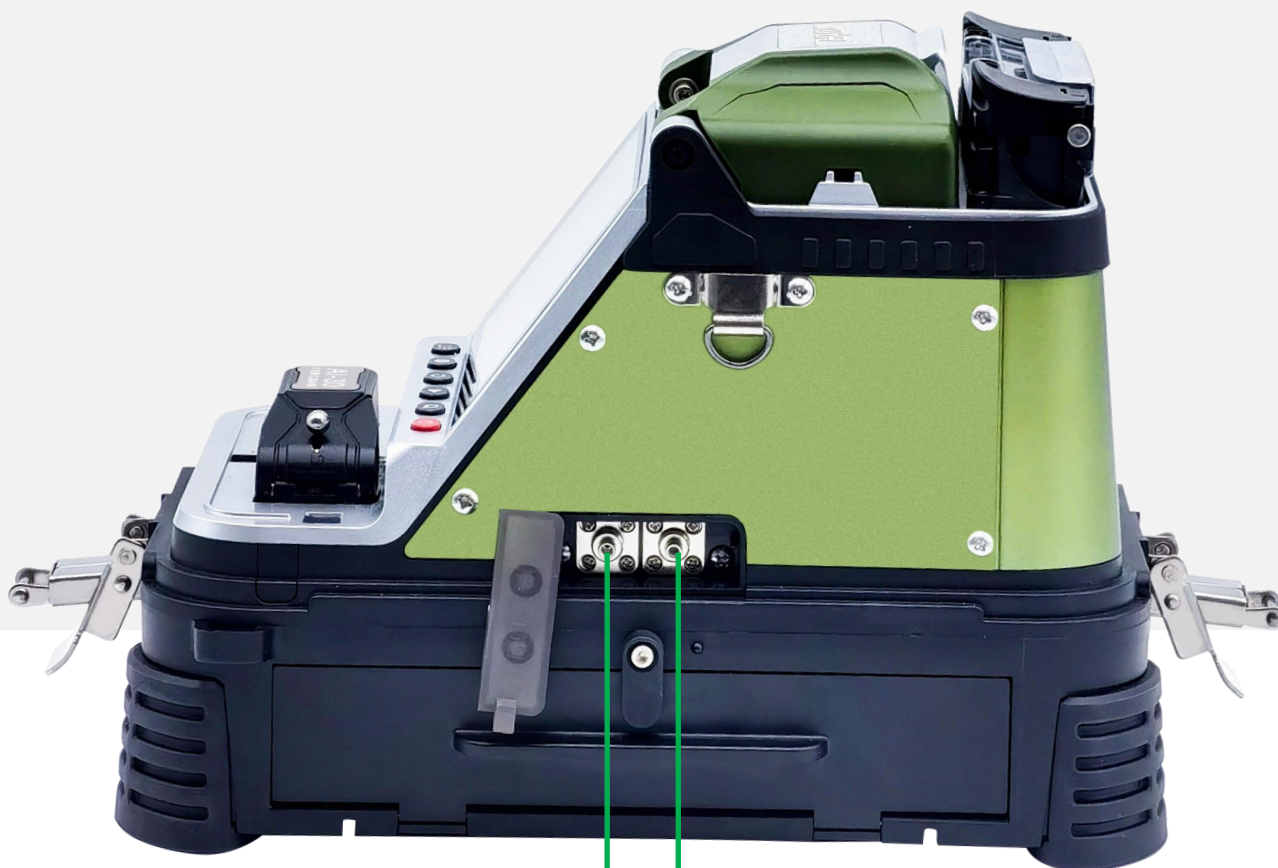

OPM(Measurement range: -50+30dbm)

VFL(10km)

OPM

Switch between ten states

Wavelength: 850nm、1300nm、1310nm
1490nm、1550nm、1625nm、980nm
1270nm、1577nm、1650nm

VFL

Switch between three states

power: 15mW, 2Hz flashing and steady on mode

Real-time luminous flux assisted alignment

Only applicable to environments with stable optical signal link from front

Intelligently analyze the alignment point with the lowest splicing loss and then splice the fiber

Splicing is completed

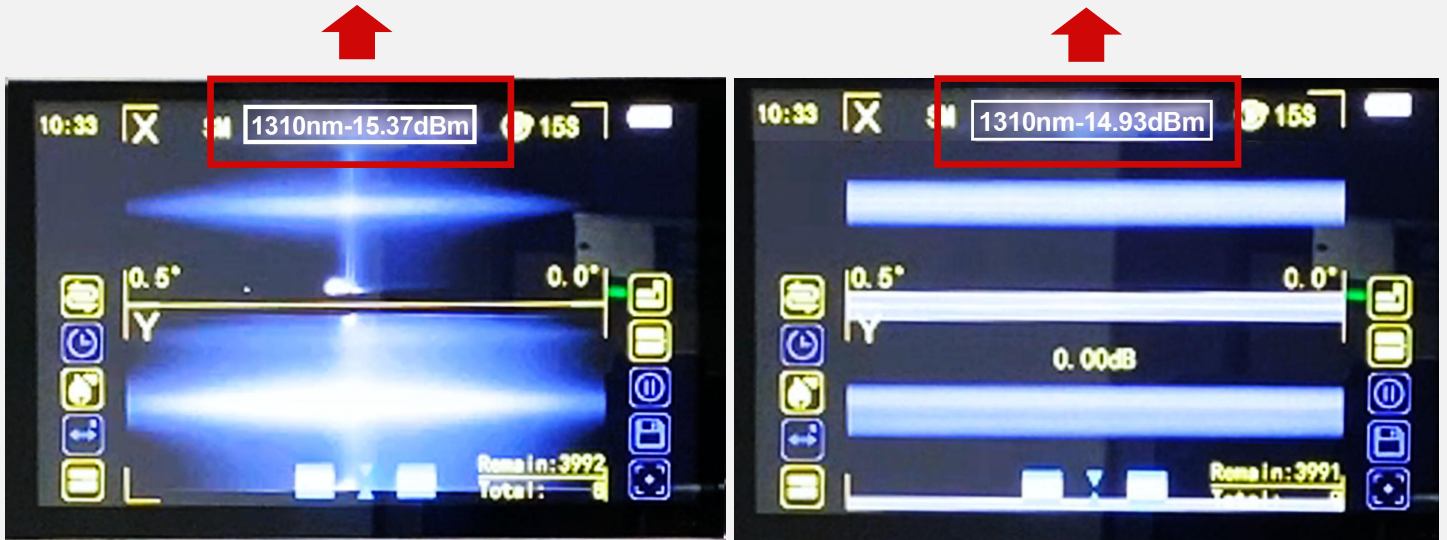

Real-time luminous flux assisted alignment technology developed by Signalfire, which intelligently analyzes the alignment point with the least loss to minimize the fiber fusion loss.

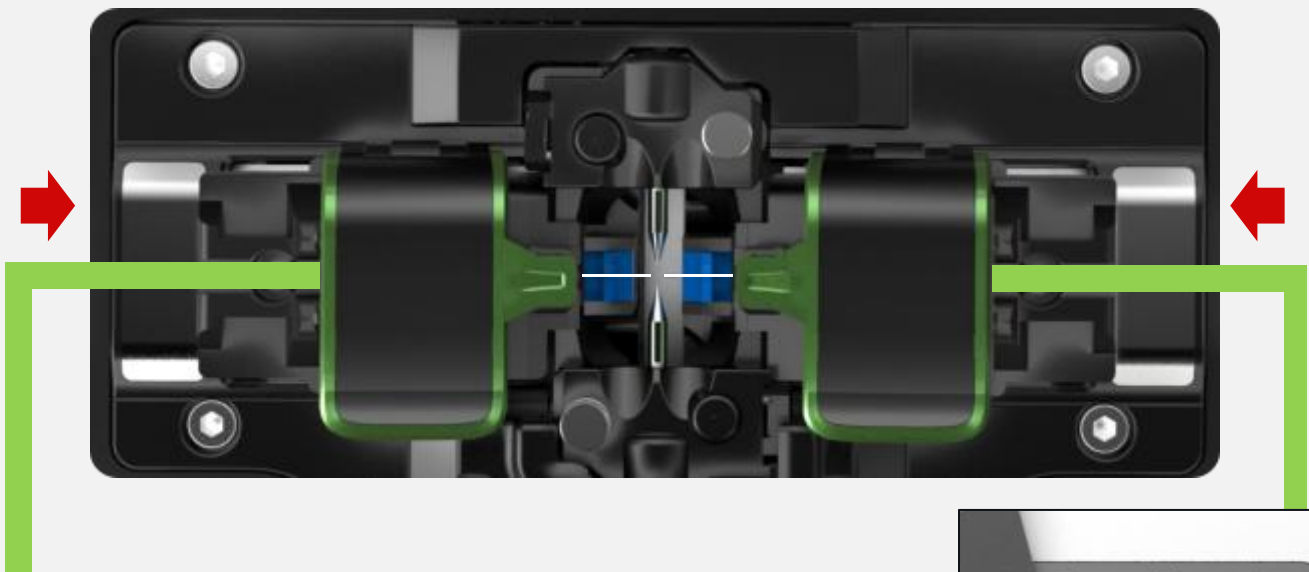

Optical fiber on the left which is stable optical signal link

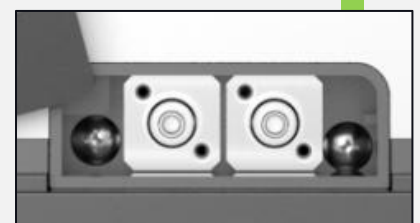

Optical Fiber on the right with fast connector which has plugged to OPM Port

Equipped with signal fire stripper



A GOOD STRIPPER NINE FUNCTIONS

- kevlar scissors
- Three-port Miller stripper
- 5G FTTH Drop cable
- Both regular FTTH Drop cable
- FTTH Drop cable steel wire pliers
- Rotary ruler
- Cleaning cotton

Signal fire stripper

5G FTTH Drop cable

Caliber: 2mm x 1.6mm

Both regular FTTH Drop cable

Caliber: 3mmx2mm

Rotary ruler

FTTH Drop cable steel wire pliers

Can not cut FRP steel wire/else steel wire
Blade maybe will scratch and have trace,
It's normal and will not influence you to use it
If you are care about this, Then please buy with cautions.

kevlar scissors

(prohibit cutting steel wires)

Three-port Miller stripper

Cleaning cotton



7800mAh lithium battery

Dual charging path

In full state, 240 cores can be continuously fused and heated



Charging channel ①

Input voltage : $13.5 \pm 0.5V$

Input current : 4.8A

Power indicator light

Charge indicator light

Indicator light turns off when fully charged

Press to check the power level

Press to popup the battery

Press the button and the battery will pop up slightly Can charge the battery separately

Charging channel ②

Charging time ≤ 3.5 hours

15S automatic heating



Preheating

Successful fiber spliced. When opening the windproof cover to take out the fiber, the machine turns on pre heating for up to 6 seconds

Heating part automatic lid closing

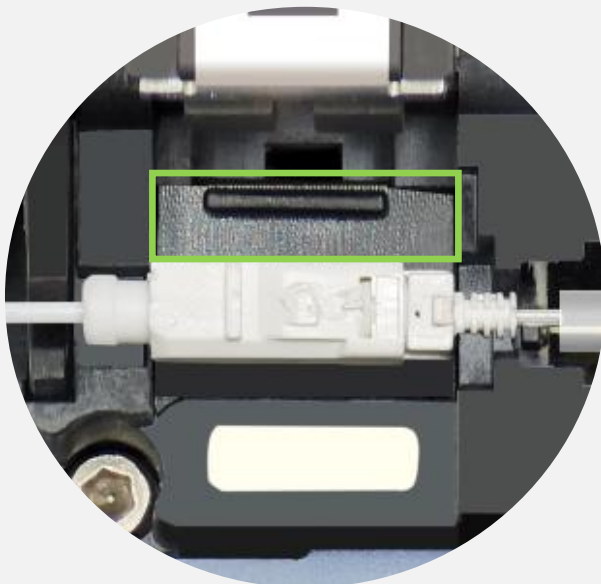

Heating part compatible with SC fiber

SC Fiber: Push up

Ordinary fiber: Push down

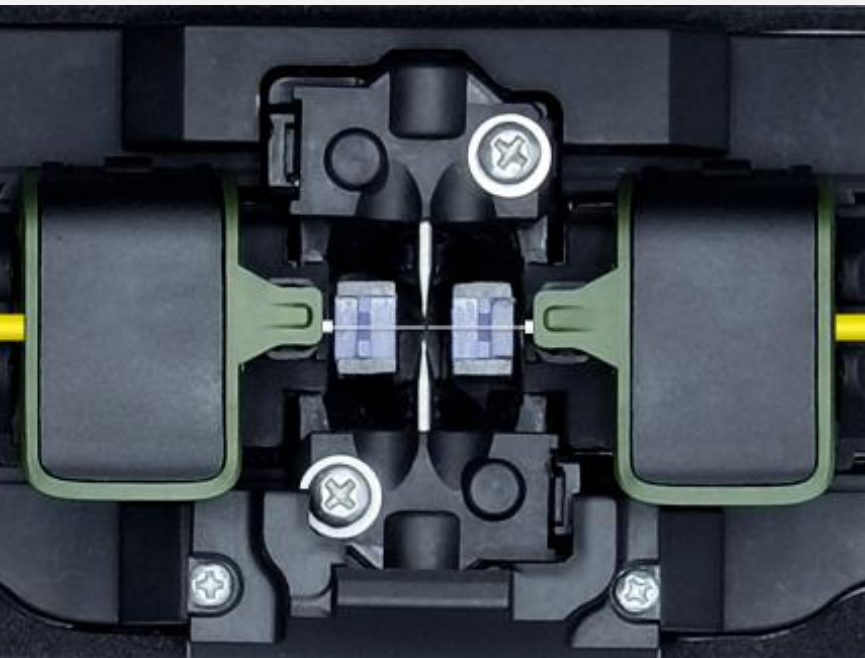

3-IN-1 UNIVERSAL FIBER HOLDER

SM, MM, bare fiber, pigtail,
Drop cable , multi fiber cable

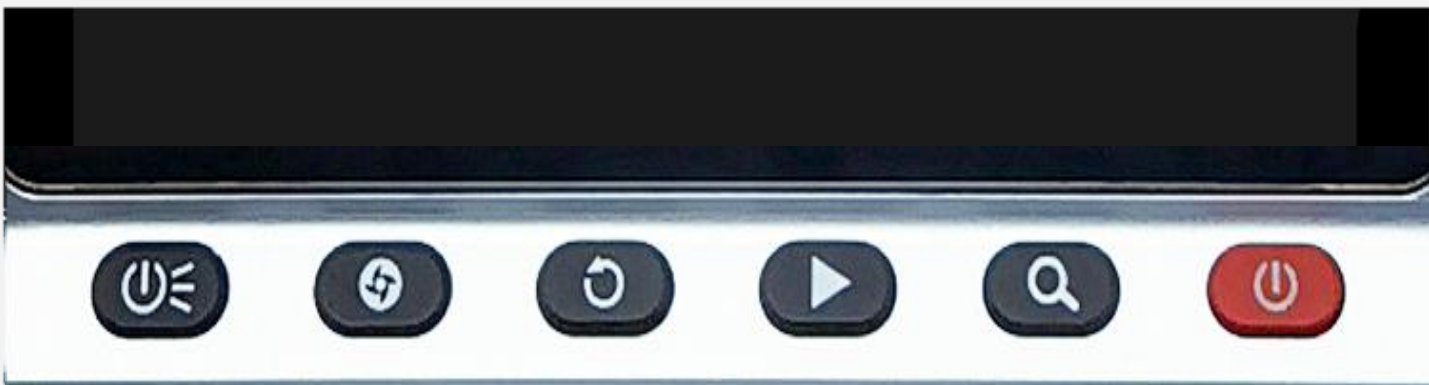
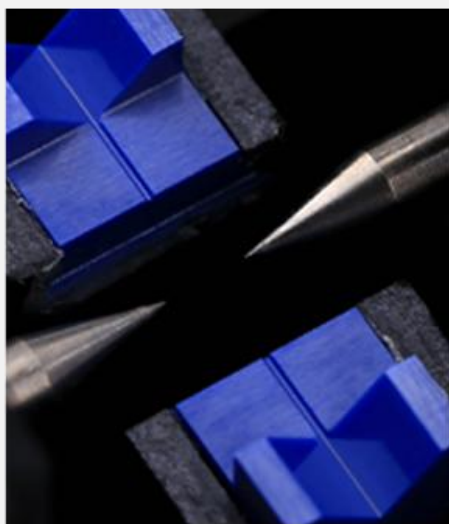

EXQUISITE DETAILS

THE BUTTONS ARE CLEAR AND BEAUTIFUL

**COOLING RACK
EXPANDABLE
AND CLOSABLE**



**ULTRA THICK
PROTECTIVE
RUBBER PAD**

Thickened buffer structure
provides maximum protection



Outdoor fiber splicing Compact and portable



Bench+support platform



Compact and portable



Combination hanging chain
Climbing homework



Compact and easy to carry

10 languages available

Multilingual Settings, covering the global market



Chinese



English

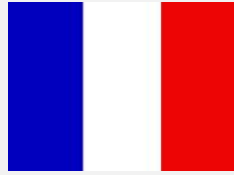

French



Russian



Italian



Portuguese



Polish



Spanish



Thai



Arabic

Exported to nearly 100 countries and regions worldwide

Get unanimous praise from customers!



Basic parameter

Fiber alignment	Core/cladding; Real-time luminous flux assisted alignment (Only applicable to environments with stable optical signal link from front)
Motor number	6 motors Accurate of fiber alignment :0.05μm
Splicing time	6s
Heating mode	15s, can be customized according to the external environment
Fiber type	Single-mode fiber (SMF/G.652), BIF/G.657); Suitable for single mode, multi-mode, bare fiber, tail fiber, drop cable, jumper, invisible optical fiber.
The cladding diameter	80-150μm
Splicing loss	0.02dB (SM) 、 0.01dB (MM) 0.04dB (DS/NZDS)
Splicing mode	Automatic focusing core alignment, conventional/high precision splicing
Splicing way	Automatic, semi-automatic,manually
Fiber cleaver	High precision delay return electric one-step fiber cleaver
Fiber holder	Three in one fixture, no need to change, suitable for single/multi-mode, multi-core cable/bare fiber, tail fiber, jumper fiber,drop cable
VFL	The machine comes with power: 15mW, 2Hz flashing and steady on mode
OPM	Wavelength: 850nm、 1300nm、 1310nm、 1490nm、 1550nm、 1625nm、 980nm、 1270nm、 1577nm、 1650nm/Measurement range: -50+30dbm Absolute error: <0.3dB (-50dbm ~+3dBm range)
Battery capacity	7800mAh large capacity lithium battery charging time ≤3.5 hours; It can continuously weld and heat about 240 cores
Magnification	320x (X or Y axis single display) , 200x (x and Y axis dual display)
Fiber diameter	Coating diameter: 80-150μm/Coating diameter: 100-1000μm
Cutting length	Coating layer 250μm below: 8-16mm/coating layer 250-1000μm: 16mm
Heat shrink tube	60mm、 50mm、 40mm、 25mm
Tensile testing	standard 2N
display	5 inch TFT color display screen
Boot time	1s, boot can enter the working mode
Data is stored	Unlimited, machine storage 1000 groups, the excess part can be stored in the server, can export data.
Wireless communication	Based on bluetooth 4.2 protocol standard, the working band is 2.4GHz, the maximum transmission range is 60m
Software upgrade	Mobile phone APP Internet update, enable Bluetooth synchronization upgrade machine software
Management function	The equipment owner can be bound as the highest authority, and can remotely view the splicing records, splicing time, loss, etc. through the mobile phone APP. The number of splicing times or working time of the equipment can be set. The manager can effectively manage a single or multiple equipment.
Return loss	Better than 60 db
Product protection	Waterproof, dustproof and fall proof
Power supply	Input AC100-240V 50/60Hz, output DC13.5V/4.8A, the current power mode can be identified, real-time monitoring of the current battery level
The work environment	Temperature: -15 ~ +50°C, humidity: < 95%RH (no condensation), working altitude: 0 ~ 5000m, maximum wind speed: ≤15m/s

Accessories in the tool box



- ① Toolcase
- ② Fusion splicer
- ③ Spare electrode
- ④ signal fire stripper
(Including a bag of cleaning cotton)
- ⑤ Alcohol bottle
- ⑥ Cleaver cleaning cotton swab
- ⑦ Allen wrench
- ⑧ Brush
- ⑨ Climbing combination hanging chain
- ⑩ Toolbox strap
- ⑪ Belt
- ⑫ Power adapter
- ⑬ User's manual / Quality Certificate / Warranty Card / Fiber for ARC

Size and weight



Machine size

165mm x 255mm x 185mm

Machine weight

3.09kg



Toolbox size

165mm x 255mm x 230mm

Weight of toolbox

(complete set) 4.50kg



Total size

340mm x 255mm x 325mm

Total weight

5.50kg

SERVICE COMMITMENT

Five years warranty, but these circumstances are not within the scope of this provision.

01. Except for the cleaver, Signal fire stripper, fiber holders and other tools whose life depends on the frequency of use and the use of the environment. Also electrodes are consumption material which are not in the warranty.

02. Battery and power adapter are warranty for one year, it is in free warranty where it is damaged or can not be charged in one year.

03. Electrodes are consumables, the service life of each pair of electrode is 4000 times.



Bluetooth Connection

Establishing wireless communication through Bluetooth technology to achieve data transmission



- Welding record can be read through mobile phone, and the data can be exported;
- You can set the parameters of the welding machine, such as selecting the machine language, changing the heating time, selecting the fiber optic alignment mode, etc;
- You can manage the welding machine, such as setting the use time of the machine, welding times, etc;
- Upgrade the phone APP, bluetooth connected to the machine to upgrade the machine software;

Intelligent interaction, avoid tedious

Scan the QR code of the welding machine startup screen to download the Mobile APP. The phone connects to the splicer via Bluetooth.

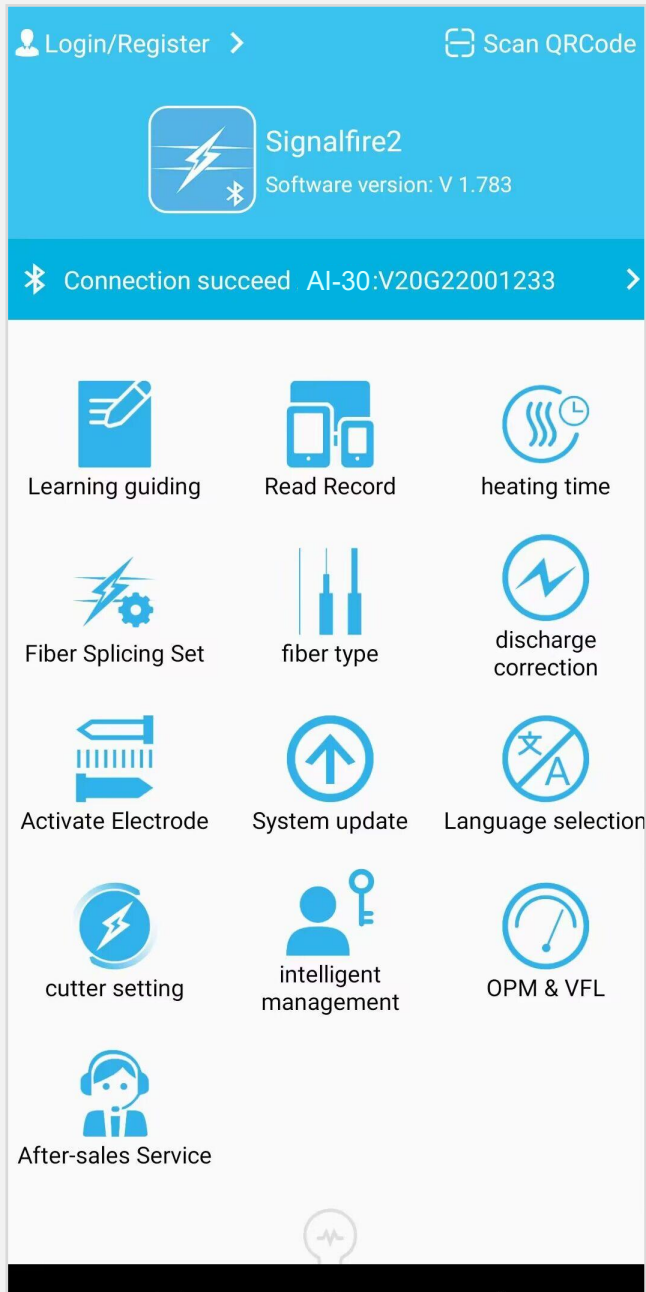

APP main interface

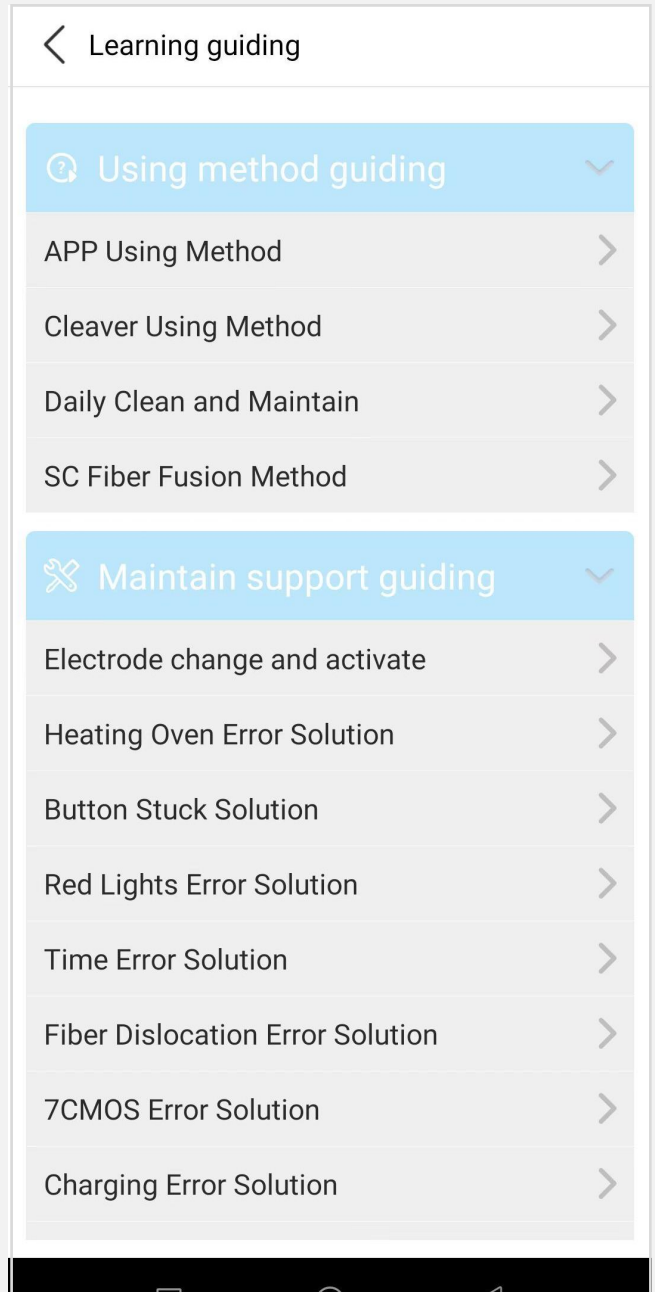

Learning guidance interface

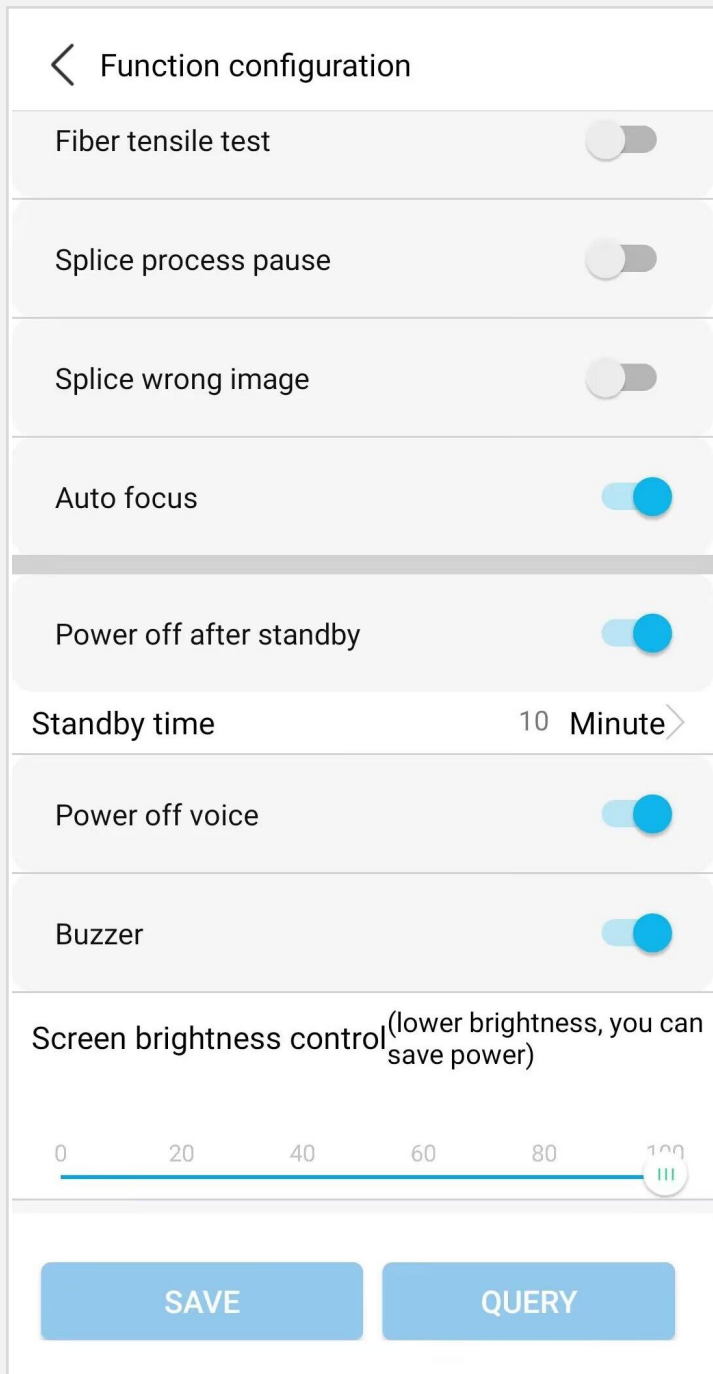

Energy saving mode

Automatic shutdown of the machine without any action within the set time

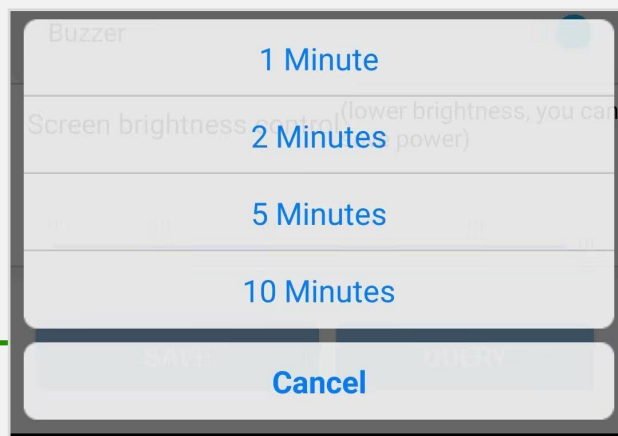

After it is opened, there will be voice prompt in the whole process from fiber laying, fiber matching, welding and loss value. In case of unqualified items, it will be directly informed.

Adapt to bright light, dark and other different outdoor environment

Splicing record More

Cumulative fusion times: 0 times

Machine: AI-30:V20G22001233

Specify user: all

View by time: 4 times

2024-09-01 - 2024-09-30

serial number	Splicing loss	Time	Weld image
1	0.00	2024-09-30 18:43:39	
2	0.01	2024-09-30 18:42:33	
3	0.01	2024-09-30 18:41:25	

Splicing records can be downloaded and exported

Unlimited storage of splicing records
Can be viewed on mobile devices

heating time

Pre-heat model

Choose shrinkable tube Customize >

Set heating time S

Preheating mode: The welding is completed. When the windshield is opened, the heater is heated in advance for 6 seconds. Turning on the preheating mode can appropriately reduce the heating time of the heat shrinkable tube to improve efficiency.

Note: In winter or low temperature, heating is not ideal, and the heating time can be

Heating time customization

Extreme cold/high temperature can be extended or shortened appropriately

Unconnected device >

中文 (简体)	Auto-detection
English	English <input checked="" type="checkbox"/>
Português	Русский
Français	Español
Русский	Italiano
Español	Português (Brasil)
Polski	Português
ไทย	Indonesia
عربي	Polski
Italiano	Français
	عربي

**Fusion splicer language/
mobile app selection**

cutter setting System parameters

Cutting length >

Cutting type Automatic identification >

Automatic cutting OFF ON

Replace the blade >

Tension automatic correction
This function can be turned off when the automatic correction function is turned on and the ideal cutting length cannot be reached. ON OFF

LED brightness adjustment

Cutter usage tutorial >

Common problems and solutions >

Clean cutter >

Factory settings >

Cutting times:72

**Cleaver Parameter setting
/adjustment**



Signal Fire Technology Co., Ltd. is a high-tech joint-stock enterprise specializing in the research and development, production, and sales of communication equipment, with a registered capital of 10 million. It is a national high-tech enterprise. Our main products include fiber optic fusion splicers, electric fiber cleaver, OTDR (Optical Time Domain Reflectometer), and 9-in-1 optical fiber stripper. They are widely used in the construction, maintenance, emergency repair, security monitoring, and research and teaching of optical cable lines in telecommunications, mobile, China Unicom, radio and television operators, post and telecommunications, railway, engineering companies, and public institutions.





The factory is located in Chengdu High tech International Enterprise Port, with a modern production factory and standardized office buildings. We have passed the ISO9001 international quality management system certification, and our products have passed the EU CE, ROHS. International certifications such as FCC in the United States and UKCA in the United Kingdom have been passed by the National Institute of Quality Supervision and Inspection, China Academy of Information and Communications Technology.







The qualified testing of Taier Laboratory has obtained nearly a hundred domestic and international patents at the same time. The "Signal Fire" series products have been sold to over 100 countries and regions including North America, South America, Europe, Africa, and Asia, and have received unanimous praise from customers.



Operator winning bid brand



Telecom installation and maintenance skills competition, Signal fire fusion splicer excellent performance, won the group first prize



Exhibition photos



Intellectual property

Signal Fire Technology Co., Ltd. has passed the ISO9001 international quality management system certification. The product has passed international certifications such as the CE, RoHS, the United States FCC, and UKCA in the United Kingdom, and passed the qualified test through National Quality Supervision Institute, China Xintong Institute, and Tel Laboratory. At the same time, we obtained nearly 100 patents.

CERTIFICATE



CERTIFICATE
Of Conformity
Directive 2014/53/EU
On The Radio Equipment Directive

Certificate No.: AT18220WC202819
Certificate Holder: SIGNAL FIRE TECHNOLOGY CO., LTD.
Address: Building 18, Chengdu Hi-Tech International Enterprise Park, Liando U Valley, 1111 Changsheng Bridge, Pidu District, Chengdu, China
Manufacturer: SIGNAL FIRE TECHNOLOGY CO., LTD.
Address: Building 18, Chengdu Hi-Tech International Enterprise Park, Liando U Valley, 1111 Changsheng Bridge, Pidu District, Chengdu, China
Product Name: OPTICAL FIBER FUSION SPLICER
Model No.: AI-9, AI-6C, AI-6V, AI-7C, AI-8C, AI-8X, AI-7V, AI-X, S9
Trade Mark: Signal fire
Rating: Input: 13.5V/4.8A DC (with DC 11V, 7800mAh Battery inside)

The radio equipment meets the following essential requirements	Complied
Article 3(1)(a) Safety	Yes
Article 3(1)(b) Health	Yes
Article 3(1)(b) EMC	Yes
Article 3(2) Radio	Yes

Note: The attached Annex forms part of this certificate which consists of 2 pages.

CE The CE Marking may only be used if all relevant and effective EU Directives are complied with **CE**

Shenzhen Anbotek Compliance Laboratory Limited
1/F, Building D, Sogood Science and Technology Park, Sanyue community, Hangsheng Street, Bao'an District, Shenzhen, Guangdong, China 518128
Tel: (86)755-26066440 Fax: (86)755-26014772
Http://www.anbotek.com Email: service@anbotek.com

CERTIFICATE

CERTIFICATE



CERTIFICATE
Of Conformity
Radio Equipment Regulations 2017
(SI 2017 No. 1206)

Certificate No.: AT18220WC202820
Certificate Holder: SIGNAL FIRE TECHNOLOGY CO., LTD.
Address: Building 18, Chengdu Hi-Tech International Enterprise Park, Liando U Valley, 1111 Changsheng Bridge, Pidu District, Chengdu, China
Manufacturer: SIGNAL FIRE TECHNOLOGY CO., LTD.
Address: Building 18, Chengdu Hi-Tech International Enterprise Park, Liando U Valley, 1111 Changsheng Bridge, Pidu District, Chengdu, China
Product Name: OPTICAL FIBER FUSION SPLICER
Model No.: AI-9, AI-6C, AI-6V, AI-7C, AI-8C, AI-8X, AI-7V, AI-X, S9
Trade Mark: Signal fire
Rating: Input: 13.5V/4.8A DC (with DC 11V, 7800mAh Battery inside)

The radio equipment meets the following essential requirements	Complied
CHAPTER 1 (General)(a) Safety	Yes
CHAPTER 1 (General)(1)(a) Health	Yes
CHAPTER 1 (General)(1)(b) EMC	Yes
CHAPTER 1 (General)(2) Radio	Yes

Note: The attached Annex forms part of this certificate which consists of 2 pages.

UK CA The UKCA Marking may only be used if all relevant and effective UK Regulations are complied with **UK CA**

Shenzhen Anbotek Compliance Laboratory Limited
1/F, Building D, Sogood Science and Technology Park, Sanyue community, Hangsheng Street, Bao'an District, Shenzhen, Guangdong, China 518128
Tel: (86)755-26066440 Fax: (86)755-26014772
Http://www.anbotek.com Email: service@anbotek.com

CERTIFICATE

CERTIFICATE

TCB GRANT OF EQUIPMENT AUTHORIZATION **TCB**

Issued Under the Authority of the Federal Communications Commission

By: Ray Area Compliance Laboratory Corp. Date of Grant: 02/09/2018
1274 Ansheng Road Sanyue, CA 94388 Application Date: 02/09/2018

Signal Fire Technology Co., Ltd.
No. 184 Qingyang Zone, Jiansheng Industrial Park
Qingyang District, Chengdu, China
Chengdu, China
Attention: Jason Yang

NOT TRANSFERABLE

EQUIPMENT AUTHORIZATION is hereby issued to the named GRANTEE, and is VALID ONLY for the equipment identified hereon for use under the Commission's Rules and Regulations listed below.

FCC IDENTIFIER: A23911739
Name of Grantee: Signal Fire Technology Co., Ltd.
Equipment Class: Digital Transmission System
Notes: OPTICAL FIBER FUSION SPLICER

Grant Notes	FCC Rule Parts	Frequency Range (MHz)	Output Watts	Frequency Tolerance	Emission Designator
	15C	2402.0 - 2484.0	0.3004		

Output power listed is conducted.



CERTIFICATE

CERTIFICATE



QUALITY MANAGEMENT SYSTEM CERTIFICATE

Certificate No.: 11423Q45347R2M

This is to certify that the Quality Management System of

SIGNAL FIRE TECHNOLOGY CO., LTD.

Unified Social Credit Code: 9151010007241028D

Registered Address: No. 1111 Changsheng Bridge, Hongqiang Town, Small and Micro Enterprise Innovation Park, North Area of Chengdu Modern Industrial Park, Pidu District, Chengdu
Production Office Address: Building 18, Chengdu High-Tech International Enterprise Park, Liando U Valley, No. 1111 Changsheng Bridge Road, Pidu District, Chengdu City, Sichuan Province, China

Has been audited to conform to the following Quality Management System standard

GB/T19001-2016/ISO9001:2015

The Applicable Scope

The production of optical fiber fusion splicer

Date of initial issuance: Aug. 22, 2017
Date of issuance: Jul. 11, 2023
Date of expiry: Jul. 21, 2025

Issued by: *Wei Fengye* Beijing East Allreach Certification Center Co., Ltd.



CERTIFICATE

